



**NIGHT RESPONDER**

**OPERATOR'S AND PARTS MANUAL**

**EFL-1**

**ALLMAND BROS. INC  
P.O. BOX 888  
HOLDREGE, NE 68949**

**PHONE: 308/995-4495, 800/562-1373  
ALLMAND FAX: 308/995-5887  
ALLMAND PARTS FAX: 308/995-4883**

**Allmand<sup>TM</sup> NIGHT RESPONDER PRODUCTS**

For Parts and Updates visit Allmand on the Web at [www.allmand.com](http://www.allmand.com)

# PRODUCT DESCRIPTION AND FEATURES

The **Allmand EFL-1** line of affordable HID lighting provides increased jobsite safety and productivity in a wide range of applications.

**Allmand EFL-1** products are built tough for years of trouble-free use. The exclusive “parallel” lamp fixtures hold the bulb in the optimum horizontal position. The insulated lamp supports isolate the bulb from damaging vibration. Average bulb life exceeds 12,000 hours of use.

## **Product Features:**

- **Sturdy welded steel frames**
- **Shock-mounted bulbs**
- **Allmand exclusive SHO parallel lamp fixtures** are the most compact and efficient HID floodlight fixtures available.
- **A 1000-watt SHO lamp** illuminates more area than ten 1000-watt quartz light stands using one 120V outlet per fixture.
- **Safe, non-metallic NEMA 4X enclosure** for high voltage ballast components
- **High-quality cords**
- **Worldwide & domestic voltages**
- **Heavy-duty ball-bearing wheels**
- **Durable plated inner towers** for long life and good appearance

## **AVAILABLE MODELS**

### **EFL-1**

Single 1000 watt SHO fixture 120V/ 9.2A

Most compact HID light cart available

Fixture stores on base

Light adjusts in all directions without tools.

103 lbs. Overall tower height of 10 ft.

# OPERATIONAL AND SAFETY DECALS



DISCONNECT ALL POWER BEFORE SERVICING. FAILURE TO FOLLOW ALL SAFETY INSTRUCTIONS CAN RESULT IN SERIOUS PERSONAL INJURY OR DEATH. INSTALL AND GROUND PER LOCAL AND NATIONAL CODES. CONSULT QUALIFIED PERSONNEL WITH QUESTIONS.

DANGER HIGH VOLTAGE  
PART NO. DD-332



LIGHT IDENTIFICATION DECAL  
PART NO. DD-333



ON-OFF DECAL  
PART NO. DD-335



GROUND LUG LOCATION  
PART NO. DD-133

# OPERATION AND SAFETY INSTRUCTIONS

## OPERATION PROCEDURES:

To remove fixture from storage on base and attach fixture to mast prior to use:

- 1) Remove safety pin retaining fixture to base and remove fixture from storage position.
- 2) Set fixture on top of mast aligning holes in mast and fixture mounting tube.
- 3) Re-install safety pin to attach fixture to mast.
- 4) Connect male three-pin connector on cord from light fixture to female three-pin receptacle on cord from ballast box mounted on base of unit.

To raise tower to desired height on EFL-1:

- 1) Pull out the pin located at top of tower base.
- 2) Extend tower to desired height.
- 3) Retain height by allowing the pin to drop into one of three holes in the tower to retain the tower at the desired height.

To operate fixture:

- 1) Plug base unit into wall socket or generator using cord attached to ballast box.
- 2) Using the On/Off switch located on the ballast box, move switch to ON position
- 3) Light will begin illuminating after brief warm-up period.

**NOTE:** Remember to wait approximately 15 minutes after shutdown of light before attempting to turn the light fixture on again. The bulb and fixture need this cool-down time before it can be re-illuminated.

## SAFETY WARNINGS:

- 1) This light product uses high voltage to perform its functions. See **DANGER HIGH VOLTAGE** decal on page four for necessary electrical safety information.
- 2) Be sure to keep the base level before elevating tower. If the base is not level, the entire unit could become unstable and prone to tipping when extending the tower .

# ASSEMBLY PARTS AND ACCESSORIES

## SHO 1000 METALLIC VAPOR LAMP ASSEMBLY

(Used on EFL-1 1000 Watt Products)

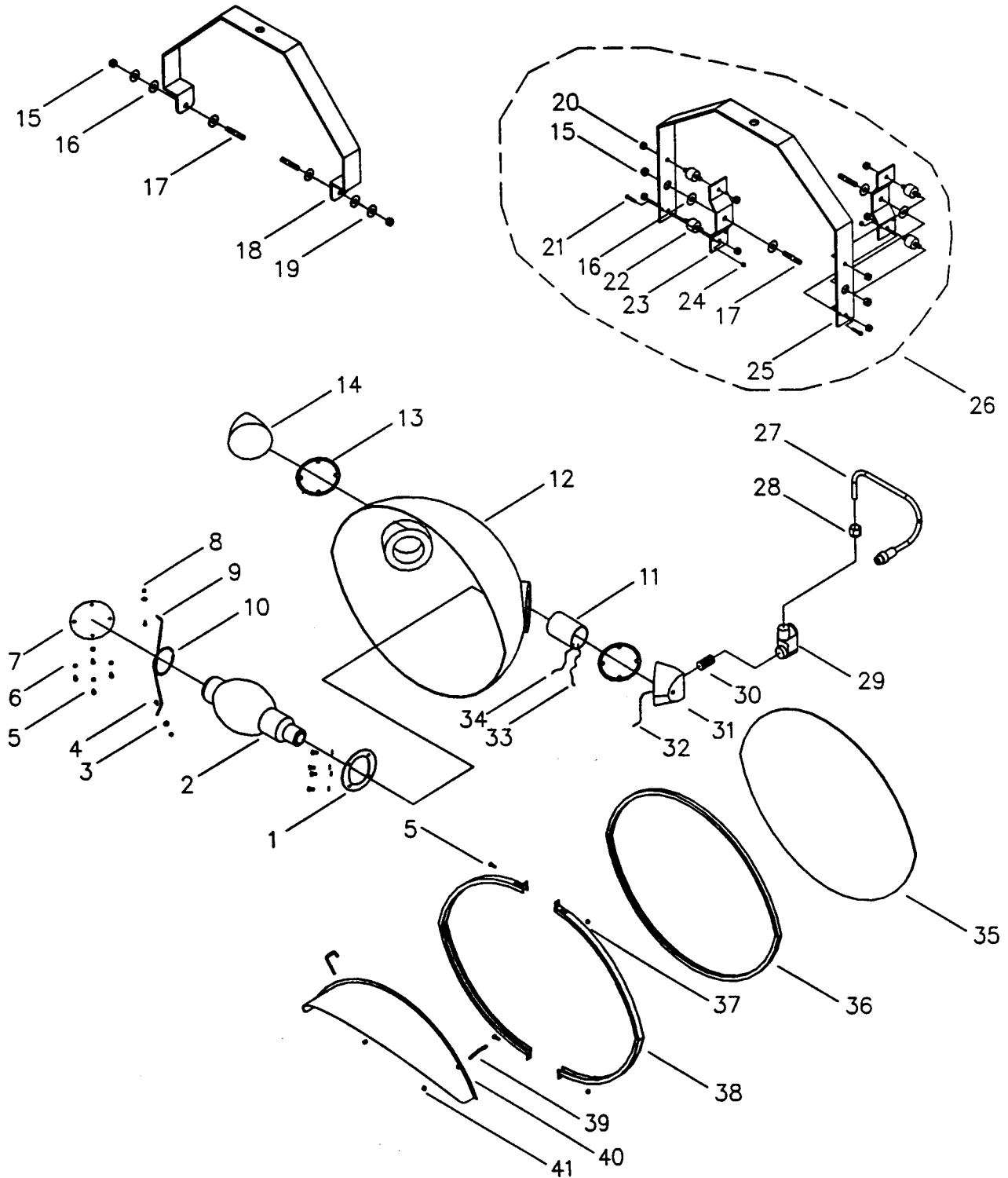

# ASSEMBLY PARTS AND ACCESSORIES

## SHO 1000 METALLIC VAPOR LAMP ASSEMBLY PARTS

(Used on EFL-1 1000 Watt Products)

NO	PART NO	DESCRIPTION
NS	610250	LAMP HOLDER ASS'Y WITH YOKE AND LAMP (SOLID MT.)
NS	610251	LAMP HOLDER ASS'Y WITH YOKE AND NO LAMP (SOLID MT.)
NS	610252	LAMP HOLDER ASSEMBLY WITH NO YOKE OR LAMP
NS	610255	LAMP HOLDER ASSEMBLY W/YOKE, LAMP AND CUSHIONS (CUSHION MT.)
NS	610253	LAMP HOLDER ASSEMBLY W/ YOKE AND CUSHIONSNO LAMP (CUSH MT.)
1	610208	ALUMINUM RING
2	610211	LAMP BT-37
NS	610218	LAMP (HIGH PRESSURE SODIUM)
3	**	8-32 WASHER (STAINLESS STEEL)
4	**	8-32 X 1/2 HEX HEAD BOLT (STAINLESS STEEL)
5	**	10- 24 X 1/2 HEX HEAD BOLT (STAINLESS STEEL)
6	**	#10 INTERNAL TOOTH WASHER
7	610207	ALUMINUM PLATE
8	**	8-32 NYLON LOCK NUT (STAINLESS STEEL)
9	610209	LAMP TIP SUPPORT
10	610210	LAMP TIP SUPPORT TUBE
11	610212	CERAMIC SOCKET
12	610201	REFLECTOR
13	610213	END HOUSING GASKET
14	610206	RH SOLID END CASTING
15	**	3/8-24 NYLON LOCK NUT (STAINLESS STEEL)
16	FW01 9	.75 OD x .385 ID x .20 NYLON WASHER
17	HD142	3/8 - 24 NF X 3/8 - 16 NC X 2" STUD
18	660130	SOLID MOUNT YOKE
19	**	3/8 SAE WASHER
20	**	5/16 - 18 KEPS NUT
21	**	10 - 24 X 1 1/2 HEX HEAD BOLT
22	610260	RUBBER SHOCK MOUNT SHO 1000
23	610235	SHO CUSHION MOUNT PLATE
24	**	10-24 NYLON LOCK NUT
25	610234	SHO 1000 CUSHION MOUNT YOKE
26	610236	SHO 1000 CUSHION MOUNT YOKE ASSEMBLY
27	310434	LAMP CONNECTOR AND LEAD
28	510007	1/2" CORD GRIP
29	610214	1/2" SLB ENTRANCE ELBOW
30	610215	1/2" CONDUIT NIPPLE
31	610205	LH SOCKET END CASTING
32	~	GREEN HEAT TEMP WIRE
33	~	BLACK HEAT TEMP WIRE
34	~	WHITE HEAT TEMP WIRE
35	610203	LENS
36	610217	LENS GASKET (SILICONE)
37	**	10-24 NYLON LOCK NUT (STAINLESS STEEL)
38	610202	LENS CHANNEL SET
39	HD070	10-24 SQ BD HOOK BOLT
40	610017	SHO 1000 LIGHT VISOR
41	**	10-24 KEPS NUT

LEGEND: NS= Not Shown  
 \*\* = Purchase locally

# ASSEMBLY PARTS AND ACCESSORIES

## EFL-1 ASSEMBLY

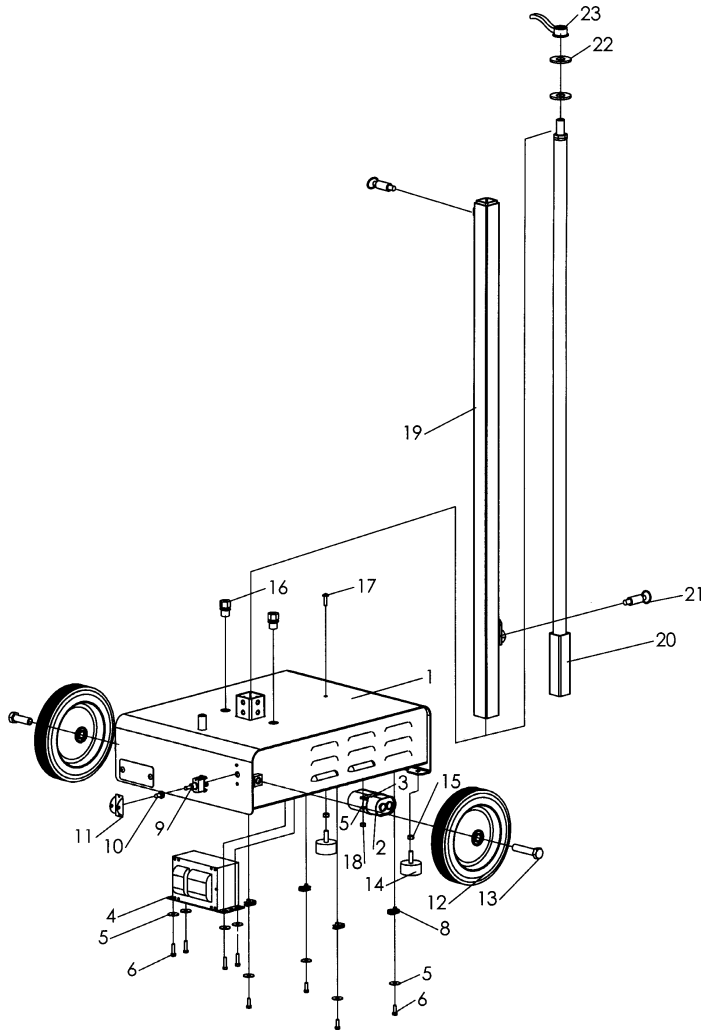

NO	REQ'D	PART NO	DESCRIPTION
1	1	530400	1250 BASE
2	1	310391	CAPACITOR 28UF 480 VOLT
3	1	026026	CUSHION CLAMP FOR CAPACITOR
4	1	310116	TRANSFORMER
5	8	047005	1/4 FLAT WASHER
6	8	046010	1/4-20 X 3/4 BOLT
7	1	530404	BASE BOTTOM COVER
8	4	045216	TINNERMAN NUT
9	1	530123	20A TOGGLE SWITCH
10	1	530124	BOOT SWITCH COVER
11	1	530125	SWITCH GUARD
12	2	530145	PNEUMATIC WHEELAND TIRE ASSY WITH 5/8 BEARING
13	2	046244	5/8-11 X 3 BOLT
14	2	713578	RUBBER BUMPER
15	2	044031	5/16-18 KEPS NUT
16	2	510007	CORD GRIP
17	1	041080	1/4-20 X 1 TRUSS HEAD PHILLIPS MACHINE SCREW
18	1	044023	1/4-20 NYLOCK NUT
19	1	530359-11	OUTSIDE MAST
20	1	530361-12	INSIDE MAST
21	2	530140	PULL PIN LARGE
22	2	650550	HDPE WASHER 3/16 X2 OD
23	1	630728	SHO HANDLE NUT
NS	4	330057	RUBBER ISOLATOR MOUNT FOR TRANSFORMER
NS	1	530127	9' SECONDARY CORD
NS	1	530136	CORD ADAPTER
NS	1	530126	6' PRIMARY CORD
NS	1	530549	ALUMINUM DIAMOND PLATE TOP COVER
NS	1	090463	EFL 1 DECAL
NS	2	830231	CHROME HANDLE

# ELECTRICAL SCHEMATICS

## EFL-1 PRODUCTS

### EFL-1 1000 Watt 60 Hz

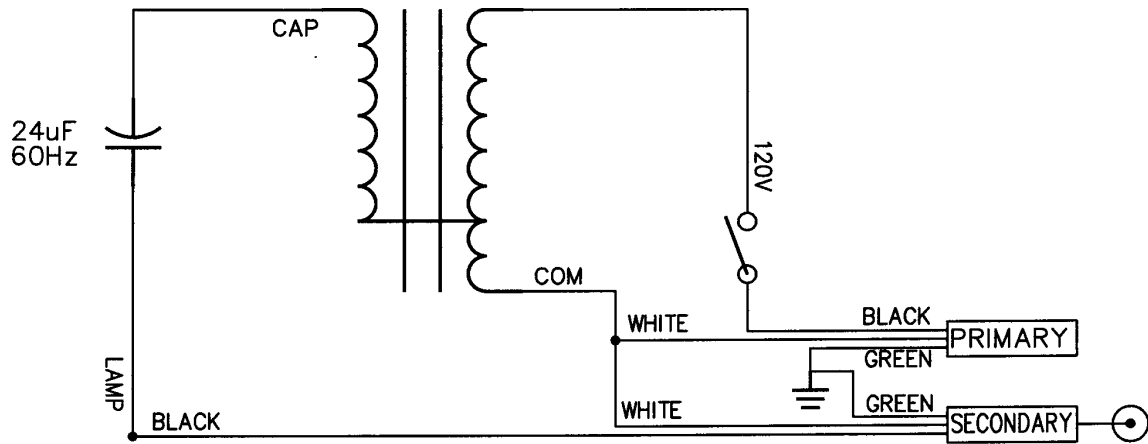

# LIMITED WARRANTY

## EFL-1 1000 Watt Products

### ALLMAND LIMITED WARRANTY

**THIS WARRANTY IS IN LIEU OF ALL OTHER WARRANTIES, EXPRESS OR IMPLIED INCLUDING WARRANTIES OF MERCHANTABILITY OR OF FITNESS FOR PURPOSE, AND ANY EXCEPTIONS ARE DESCRIBED IN THE PUBLISHED LIMITED WARRANTY ADDENDUM, AVAILABLE UPON REQUEST.**

**COMPONENTS, SUB-ASSEMBLIES AND DEVICES MANUFACTURED BY OTHER MANUFACTURERS ARE NOT COVERED BY THIS WARRANTY AND ALL WARRANTY INFORMATION FROM SUCH OTHER MANUFACTURERS IS PROVIDED WITHIN OR ACCOMPANY THESE GOODS.**

Subject to the foregoing, the manufacturer, Allmand Bros. Inc., hereby warrants all equipment manufactured by Allmand Bros. Inc. to be free from defects in material and workmanship for a period of one (1) year after delivery to the original purchaser, or eighteen (18) months after shipment from the factory, whichever comes first. Additionally, Allmand Bros. Inc., hereby warrants all replacement parts supplied by Allmand Bros. Inc. to be free from defects in material and workmanship for a period of 90 days after date of invoice. Delivery shall be deemed for the purposes of this warranty to have occurred no later than five days following the date of sale agreement or invoice unless the purchase agreement or invoice specifically states a later delivery date in which case such delivery date shall control. The original purchaser shall be deemed to be a person who places the goods or products in actual use, and any person holding such goods solely for wholesale or retail sale purposes shall not constitute an original purchaser. PROVIDED, any leasing of these goods or other use beyond normal demonstration of same shall be deemed to be a use by an original purchaser and all warranty periods shall commence at the time of such use. During the warranty period any defective goods or parts hereof shall be repaired or replaced at manufacturer's discretion. In the event it is necessary to return such goods or parts to the factory, all transportation charges shall be prepaid. The manufacturer shall in no event pay mileage expenses, but will warrant outbound ground freight.

The obligations of the manufacturer is solely to repair or replace defective goods or parts or to refund the cost of the same if it is determined by the manufacturer that repair or replacement will not return the goods to proper working order or utility. **THE REMEDIES SET FORTH HEREIN ARE EXCLUSIVE AND MANUFACTURER SHALL NOT BE LIABLE FOR SPECIAL, INDIRECT OR CONSEQUENTIAL DAMAGES. THE OBLIGATIONS OF THE MANUFACTURER HEREUNDER SHALL IN NO WAY EXCEED THE PRICE OF THE EQUIPMENT OR PART UPON WHICH SUCH LIABILITY IS BASED.**

The warranty shall not extend to tires, lamps and batteries or parts which have been altered, changed, damaged or improperly installed, repaired, operated or maintained. Provided, this exclusion shall not apply to installations, repairs or other work done at the manufacturer's plant or under direct manufacturer's supervision. The Operator's Manual, to the extent covered therein, is deemed to set forth the proper procedures for operation, repair, installation and maintenance of these goods.

No representative, dealer or distributor of the company is authorized to make any changes or exceptions to this warranty unless expressly authorized in writing from the manufacturer. All warranty claims must be filed within forty-five (45) days of the failure.

**ALLMAND BROS. INC., 1502 W 4<sup>TH</sup> AVENUE, P.O. BOX 888, HOLDREGE, NE 68949 (308) 995-4495**

ALLMAND LIMITED WARRANTY 1 YR/7.02.01

